



MC07 Non-Metallic Pumps

- Polypropylene
- PVDF

Assembly, Installation and Operation Manual Design Level 1



www.mcpump.us

REV 2100

MC

1: PUMP SPECS

2: INSTAL & OP

3: EXP VIEW

Safety Information

IMPORTANT



Read the safety warnings and instructions in this manual before pump installation and start-up. Failure to comply with the recommendations stated in this manual could damage the pump and void factory.



When the pump is used for materials that tend to settle out or solidify, the pump should be flushed after each use to prevent damage. In freezing temperatures the pump should be completely drained between uses.

CAUTION



Before pump operation, inspect all fasteners for loosening caused by gasket creep. Retighten loose fasteners to prevent leakage. Follow recommended torques stated in this manual.



Nonmetallic pumps and plastic components are not UV stabilized. Ultraviolet radiation can damage these parts and negatively affect material properties. Do not expose to UV light for extended periods of time.

WARNING



When used for toxic or aggressive fluids, the pump should always be flushed clean prior to disassembly.



Before maintenance or repair, shut off the compressed air line, bleed the pressure, and disconnect the air line from the pump. Be certain that approved eye protection and protective clothing are worn at all times. Failure to follow these recommendations may result in serious injury or death.



Airborne particles and loud noise hazards. Wear eye and ear protection.



In the event of diaphragm rupture, pumped material may enter the air end of the pump, and be discharged into the atmosphere. If pumping a product that is hazardous or toxic, the air exhaust must be piped to an appropriate area for safe containment.



Take action to prevent static sparking. Fire or explosion can result, especially when handling flammable liquids. The pump, piping, valves, containers and other miscellaneous equipment must be properly grounded.



This pump is pressurized internally with air pressure during operation. Make certain that all fasteners and piping connections are in good condition and are reinstalled properly during reassembly.



Use safe practices when lifting

Explanation of Pump Nomenclature

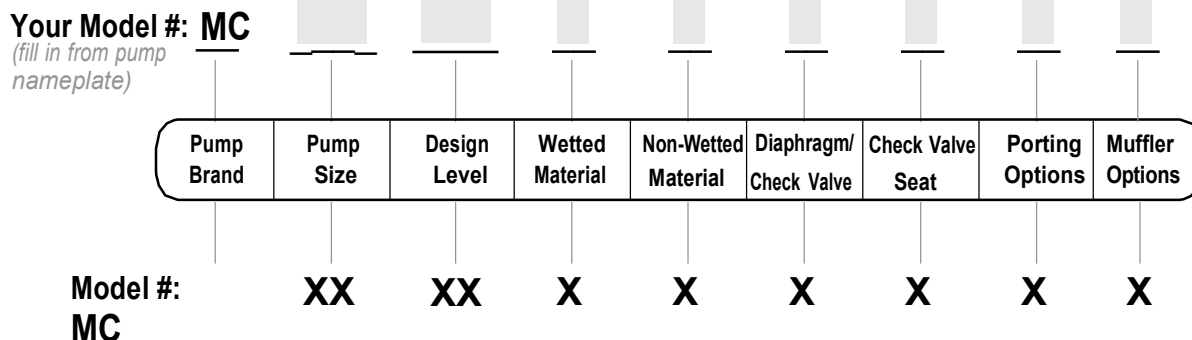

Pump Brand

MC MC Pump[®]

Pump Size

07 3/4"

Design Level

01 Design Level

Wetted Material

P Polypropylene

K PVDF

Non-Wetted Material Options

P Polypropylene

Diaphragm/Check Valve Materials

1 Santoprene/Santoprene

2 PTFE-Santoprene/PTFE

3 Neoprene/Santoprene

4 Hytrel/Santoprene

5 Nitrile/PTFE

6 Hytrel/Neoprene

B Nitrile/Nitrile

C Viton/PTFE

E EPDM/EPDM

G PTFE-Neoprene/PTFE

H Hytrel/Hytrel

I EPDM/Santoprene

M Santoprene/PTFE

N Neoprene/Neoprene

T PTFE-Nitrile/PTFE

V FKM/FKM

Check Valve Seat

P Polypropylene

K PVDF

Porting Options

N NPT Threads

B BSPT Threads

Muffler Options

0 Body Connected Muffler

6 Metal Muffler

Record the model number and serial number below for future reference. This is important information when ordering replacement parts or when technical assistance is required.

Your Pump Model #: _____

Your Serial #: _____

Performance

MC07 NON-METALLIC

Model MC07 Non-Metallic Performance Curve

1: PUMP SPECS

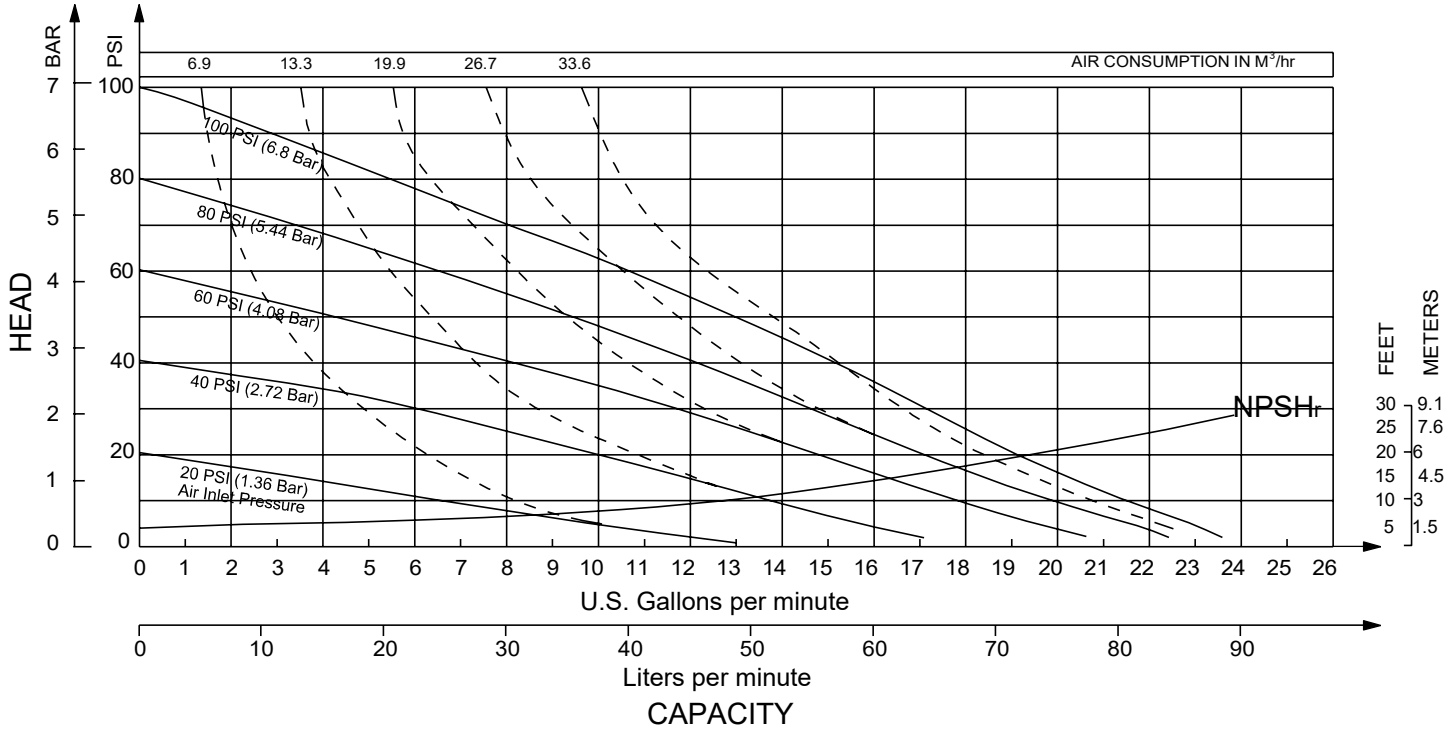

SUCTION/DISCHARGE PORT SIZE

- 3/4" NPT (Internal) and 1 1/2" NPT (External)
- 3/4" BSPT (Internal) and 1 1/2" BSPT (External)

CAPACITY

- 0 to 24 gallons per minute
(0 to 90 liters per minute)

AIR DISTRIBUTION VALVE

- No-lube, no-stall design

SOLIDS-HANDLING

- Up to 0.15 in. (4mm)

HEADS UP TO

- 100 psi or 231 ft. of water
(7 bar or 70 meters)

DISPLACEMENT/STROKE

- 0.026 Gallon / 0.098 liter

MAX OPERATING PRESSURE

- 100 psi (7 bar)

SHIPPING WEIGHT

- Polypropylene 13.7 lbs. (6.2kg)
- PVDF 17.6 lbs. (8kg)

Materials

Material Profile:	Operating Temperatures:	
	Max.	Min.
▲ CAUTION! Operating temperature limitations are as follows:		
Conductive Acetal: Tough, impact resistant, ductile. Good abrasion resistance and low friction surface. Generally inert, with good chemical resistance except for strong acids and oxidizing agents.	190°F 88°C	-20°F -29°C
EPDM: Shows very good water and chemical resistance. Has poor resistance to oils and solvents, but is fair in ketones and alcohols.	280°F 138°C	-40°F -40°C
FKM: (Fluorocarbon) Shows good resistance to a wide range of oils and solvents; especially all aliphatic, aromatic and halogenated hydrocarbons, acids, animal and vegetable oils. Hot water or hot aqueous solutions (over 70°F(21°C)) will attack FKM.	350°F 177°C	-40°F -40°C
Hytrel: Good on acids, bases, amines and glycols at room temperatures only.	220°F 104°C	-20°F -29°C
Neoprene: All purpose. Resistance to vegetable oils. Generally not affected by moderate chemicals, fats, greases and many oils and solvents. Generally attacked by strong oxidizing acids, ketones, esters and nitro hydrocarbons and chlorinated aromatic hydrocarbons.	200°F 93°C	-10°F -23°C
Nitrile: General purpose, oil-resistant. Shows good solvent, oil, water and hydraulic fluid resistance. Should not be used with highly polar solvents like acetone and MEK, ozone, chlorinated hydrocarbons and nitro hydrocarbons.	190°F 88°C	-10°F -23°C
Nylon: 6/6 High strength and toughness over a wide temperature range. Moderate to good resistance to fuels, oils and chemicals.	180°F 82°C	32°F 0°C
Polypropylene: A thermoplastic polymer. Moderate tensile and flex strength. Resists strong acids and alkali. Attacked by chlorine, fuming nitric acid and other strong oxidizing agents.	180°F 82°C	32°F 0°C
PVDF: (Polyvinylidene Fluoride) A durable fluoroplastic with excellent chemical resistance. Excellent for UV applications. High tensile strength and impact resistance.	250°F 121°C	0°F -18°C
Santoprene: Injection molded thermoplastic elastomer with no fabric layer. Long mechanical flex life. Excellent abrasion resistance.	275°F 135°C	-40°F -40°C
UHMW PE: A thermoplastic that is highly resistant to a broad range of chemicals. Exhibits outstanding abrasion and impact resistance, along with environmental stress-cracking resistance.	180°F 82°C	-35°F -37°C
Urethane: Shows good resistance to abrasives. Has poor resistance to most solvents and oils.	150°F 66°C	32°F 0°C
Virgin PTFE: (PFA/TFE) Chemically inert, virtually impervious. Very few chemicals are known to chemically react with PTFE; molten alkali metals, turbulent liquid or gaseous fluorine and a few fluoro-chemicals such as chlorine trifluoride or oxygen difluoride which readily liberate free fluorine at elevated temperatures.	220°F 104°C	-35°F -37°C
<i>Maximum and Minimum Temperatures are the limits for which these materials can be operated. Temperatures coupled with pressure affect the longevity of diaphragm pump components. Maximum life should not be expected at the extreme limits of the temperature ranges.</i>		
Metals:		
Alloy C: Equal to ASTM494 CW-12M-1 specification for nickel and nickel alloy.		
Stainless Steel: Equal to or exceeding ASTM specification A743 CF-8M for corrosion resistant iron chromium, iron chromium nickel and nickel based alloy castings for general applications. Commonly referred to as 316 Stainless Steel in the pump industry.		
For specific applications, always consult the Chemical Resistance Chart.		

Ambient temperature range: -20°C to +40°C

Process temperature range: -20°C to +80°C for models rated as category 1 equipment
-20°C to +100°C for models rated as category 2 equipment

In addition, the ambient temperature range and the process temperature range do not exceed the operating temperature range of the applied non-metallic parts as listed in the manuals of the pumps.

Dimensional Drawings for MC07 Non-Metallic Pumps

1: PUMP SPECS

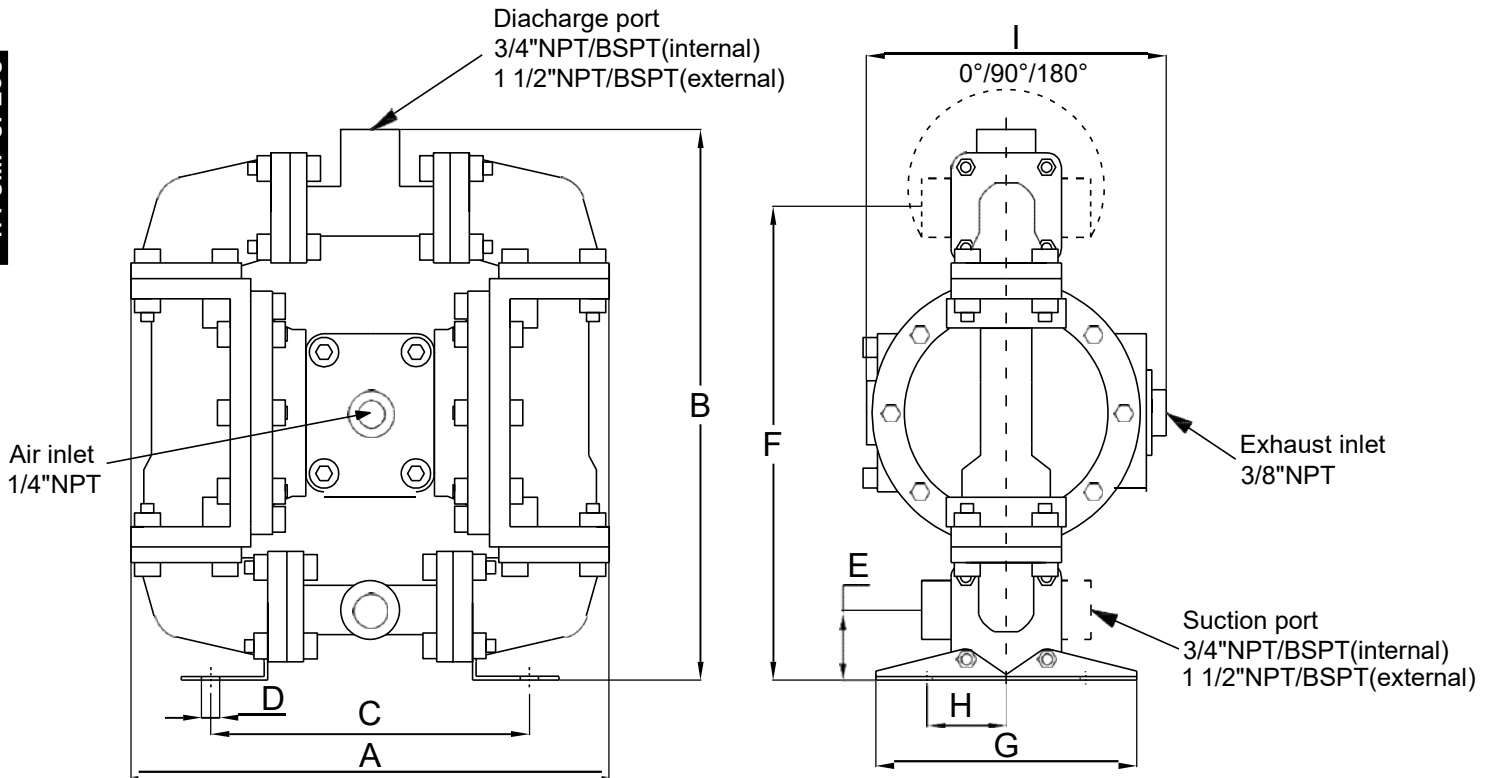

Dimension Tolerance :±5mm or ±0.2"

Pump Model	A	B	C	D	E	F	G	H	I mm/inches		Weight (kg)
	mm inches	mm inches	mm inches	mm inches	mm inches	mm inches	mm inches	mm inches	standard muffler	metal muffler	
MC07N M	300 11.81"	357 14.06"	184 7.24"	9 0.36"	64 2.52"	297 11.69"	143 5.63"	57 2.24"	179 7.05"	222 8.74"	PP:6.2 PVDF:8

Troubleshooting Guide

Symptom:	Potential Cause(s):	Recommendation(s):
Pump Cycles Once	Deadhead (system pressure meets or exceeds air supply pressure).	Increase the inlet air pressure to the pump. Pump is designed for 1:1 pressure ratio at zero flow. (Does not apply to high pressure 2:1 units).
	Air valve or intermediate gaskets installed incorrectly.	Install gaskets with holes properly aligned.
	Bent or missing actuator plunger.	Remove pilot valve and inspect actuator plungers.
Pump Will Not Operate / Cycle	Pump is over lubricated.	Set lubricator on lowest possible setting or remove. Units are designed for lube free operation.
	Lack of air (line size, PSI, CFM).	Check the air line size and length, compressor capacity (HP vs. CFM required).
	Check air distribution system.	Disassemble and inspect main air distribution valve, pilot valve and pilot valve actuators.
	Discharge line is blocked or clogged manifolds.	Check for inadvertently closed discharge line valves. Clean discharge manifolds/piping.
	Deadhead (system pressure meets or exceeds air supply pressure).	Increase the inlet air pressure to the pump. Pump is designed for 1:1 pressure ratio at zero flow. (Does not apply to high pressure 2:1 units).
	Blocked air exhaust muffler.	Remove muffler screen, clean or de-ice, and re-install.
	Pumped fluid in air exhaust muffler.	Disassemble pump chambers. Inspect for diaphragm rupture or loose diaphragm plate assembly.
Pump Cycles and Will Not Prime or No Flow	Pump chamber is blocked.	Disassemble and inspect wetted chambers. Remove or flush any obstructions.
	Cavitation on suction side.	Check suction condition (move pump closer to product).
	Check valve obstructed. Valve ball(s) not seating properly or sticking.	Disassemble the wet end of the pump and manually dislodge obstruction in the check valve pocket. Clean out around valve ball cage and valve seat area. Replace valve ball or valve seat if damaged. Use heavier valve ball material.
	Valve ball(s) missing (pushed into chamber or manifold).	Worn valve ball or valve seat. Worn fingers in valve ball cage (replace part). Check Chemical Resistance Guide for compatibility.
	Valve ball(s) / seat(s) damaged or attacked by product.	Check Chemical Resistance Guide for compatibility.
	Check valve and/or seat is worn or needs aMCusting.	Inspect check valves and seats for wear and proper setting. Replace if necessary.
	Suction line is blocked.	Remove or flush obstruction. Check and clear all suction screens or strainers.
	Excessive suction lift.	For lifts exceeding 20' of liquid, filling the chambers with liquid will prime the pump in most cases.
	Suction side air leakage or air in product.	Visually inspect all suction-side gaskets and pipe connections.
	Pumped fluid in air exhaust muffler.	Disassemble pump chambers. Inspect for diaphragm rupture or loose diaphragm plate assembly.
	Pump Cycles Running Sluggish / Stalling, Flow Unsatisfactory	Over lubrication.
Icing.		Remove muffler screen, de-ice, and re-install. Install a point of use air drier.
Clogged manifolds.		Clean manifolds to allow proper air flow.
Deadhead (system pressure meets or exceeds air supply pressure).		Increase the inlet air pressure to the pump. Pump is designed for 1:1 pressure ratio at zero flow. (Does not apply to high pressure 2:1 units).
Cavitation on suction side.		Check suction (move pump closer to product).
Lack of air (line size, PSI, CFM).		Check the air line size, length, compressor capacity.
Excessive suction lift.		For lifts exceeding 20' of liquid, filling the chambers with liquid will prime the pump in most cases.
Air supply pressure or volume exceeds system hd.		Decrease inlet air (press. and vol.) to the pump. Pump is cavitating the fluid by fast cycling.
Undersized suction line.		Meet or exceed pump connections.
Restrictive or undersized air line.		Install a larger air line and connection.
Suction side air leakage or air in product.		Visually inspect all suction-side gaskets and pipe connections.
Suction line is blocked.		Remove or flush obstruction. Check and clear all suction screens or strainers.
Pumped fluid in air exhaust muffler.		Disassemble pump chambers. Inspect for diaphragm rupture or loose diaphragm plate assembly.
Check valve obstructed.		Disassemble the wet end of the pump and manually dislodge obstruction in the check valve pocket.
Check valve and/or seat is worn or needs aMCusting.		Inspect check valves and seats for wear and proper setting. Replace if necessary.
Product Leaking Through Exhaust	Entrained air or vapor lock in chamber(s).	Purge chambers through tapped chamber vent plugs. Purging the chambers of air can be dangerous.
	Diaphragm failure, or diaphragm plates loose.	Replace diaphragms, check for damage and ensure diaphragm plates are tight.
Premature Diaphragm Failure	Diaphragm stretched around center hole or bolt holes.	Check for excessive inlet pressure or air pressure. Consult Chemical Resistance Chart for compatibility with products, cleaners, temperature limitations and lubrication.
	Cavitation.	Enlarge pipe diameter on suction side of pump.
	Excessive flooded suction pressure.	Move pump closer to product. Raise pump/place pump on top of tank to reduce inlet pressure. Install Back pressure device (Tech bulletin 41r). Add accumulation tank or pulsation dampener.
	Misapplication (chemical/physical incompatibility).	Consult Chemical Resistance Chart for compatibility with products, cleaners, temperature limitations and lubrication.
Unbalanced Cycling	Incorrect diaphragm plates or plates on backwards, installed incorrectly or worn.	Check Operating Manual to check for correct part and installation. Ensure outer plates have not been worn to a sharp edge.
	Excessive suction lift.	For lifts exceeding 20' of liquid, filling the chambers with liquid will prime the pump in most cases.
	Undersized suction line.	Meet or exceed pump connections.
	Pumped fluid in air exhaust muffler.	Disassemble pump chambers. Inspect for diaphragm rupture or loose diaphragm plate assembly.
	Suction side air leakage or air in product.	Visually inspect all suction-side gaskets and pipe connections.
	Check valve obstructed.	Disassemble the wet end of the pump and manually dislodge obstruction in the check valve pocket.
Product Leaking Through Exhaust	Check valve and/or seat is worn or needs aMCusting.	Inspect check valves and seats for wear and proper setting. Replace if necessary.
	Entrained air or vapor lock in chamber(s).	Purge chambers through tapped chamber vent plugs.

Diaphragm Servicing

Step 1: With manifolds and outer chambers removed, remove diaphragm assemblies from diaphragm rod. **DO NOT** use a pipe wrench or similar tool to remove assembly from rod. Flaws in the rod surface may damage bearings and seal. Soft jaws in a vise are recommended to prevent diaphragm rod damage.

Step 1.A: NOTE: Not all inner diaphragm plates are threaded. Some models utilize a through hole in the inner diaphragm plate. If required to separate diaphragm assembly, place assembly in a vise, gripping on the exterior cast diameter of the inner plate. Turn the outer plate clockwise to separate the assembly.

Always inspect diaphragms for wear cracks or chemical attack. Inspect inner and outer plates for deformities, rust scale and wear. Inspect intermediate bearings for elongation and wear. Inspect diaphragm rod for wear or marks.

Clean or repair if appropriate. Replace as required.

Step 2: Reassembly: There are two different types of diaphragm plate assemblies utilized throughout the MC Pump product line: Outer plate with a threaded stud, diaphragm, and a threaded inner plate.

Outer plate with a threaded stud, diaphragm, and an inner plate with through hole. Secure threaded inner plate in a vise. Ensure that the plates are being installed with the outer radius against the diaphragm.

Step 3: Lightly lubricate, with a compatible material, the inner faces of both outer and inner diaphragm plates when using on non Overlay diaphragms (For EPDM water is recommended). No lubrication is required.

Step 4: Push the threaded outer diaphragm plate through the center hole of the diaphragm. **Note:** Most diaphragms are installed with the natural bulge out towards the fluid side. 05, 07, and 10 non-metallic units are installed with the natural bulge in towards the air side.

Step 5: Thread or place, outer plate stud into the inner plate. For threaded inner plates, use a torque wrench to tighten the assembly together. Torque values are called out on the exploded view.

Repeat procedure for second side assembly. Allow a minimum of 15 minutes to elapse after torquing, then re-torque the assembly to compensate for stress relaxation in the clamped assembly.

Step 6: Thread one assembly onto the diaphragm rod with sealing washer (when used) and bumper.

Step 7: Install diaphragm rod assembly into pump and secure by installing the outer chamber in place and tightening the capscrews.

Step 8: On opposite side of pump, thread the remaining assembly onto the diaphragm rod. Using a torque wrench, tighten the assembly to the diaphragm rod. Align diaphragm through bolt holes, always going forward past the recommended torque. Torque values are called out on the exploded view. **NEVER** reverse to align holes, if alignment cannot be achieved without damage to diaphragm, loosen complete assemblies, rotate diaphragm and reassemble as described above.

Step 9: Complete assembly of entire unit. One Piece Diaphragm Servicing (Bonded PTFE with integral plate) The One Piece diaphragm has a threaded stud installed in the integral plate at the factory. The inner diaphragm plate has a through hole instead of a threaded hole. Place the inner plate over the diaphragm stud and thread the first diaphragm / inner plate onto the diaphragm rod only until the inner plate contacts the rod. Do not tighten. A small amount of grease may be applied between the inner plate and the diaphragm to facilitate assembly. Insert the diaphragm / rod assembly into the pump and install the outer chamber. Turn the pump over and thread the second diaphragm / inner plate onto the diaphragm rod. Turn the diaphragm until the inner plate contacts the rod and hand tighten the assembly. Continue tightening until the bolt holes align with the inner chamber holes. **DO NOT LEAVE THE ASSEMBLY LOOSE**

IMPORTANT



Read these instructions completely, before installation and start-up. It is the responsibility of the purchaser to retain this manual for reference. Failure to comply with the recommendations stated in this manual will damage the pump, and void factory.

Recommended Installation Guide

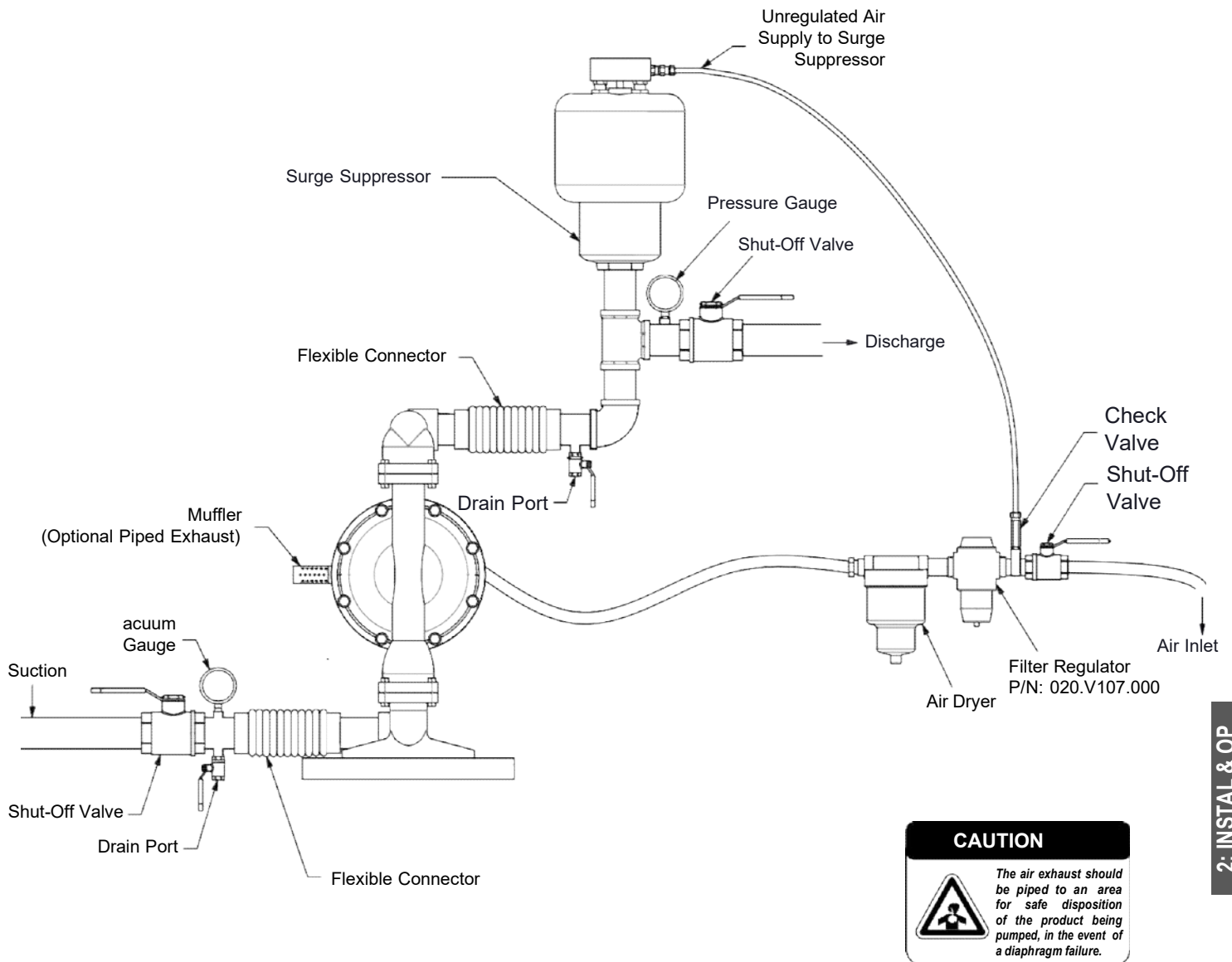

2: INSTAL & OP

Installation And Start-Up

Locate the pump as close to the product being pumped as possible. Keep the suction line length and number of fittings to a minimum. Do not reduce the suction line diameter.

Air Supply

Connect the pump air inlet to an air supply with sufficient capacity and pressure to achieve desired performance. A pressure regulating valve should be installed to insure air supply pressure does not exceed recommended limits.

Air Valve Lubrication

The air distribution system is designed to operate WITHOUT lubrication. This is the standard mode of operation. If lubrication is desired, install an air line lubricator set to deliver one drop of SAE 10 non-detergent oil for every 20 SCFM (9.4 liters/sec.) of air the pump consumes. Consult the Performance Curve to determine air consumption.

Air Line Moisture

Water in the compressed air supply may cause icing or freezing of the exhaust air, causing the pump to cycle erratically or stop operating. Water in the air supply can be reduced by using a point-of-use air dryer.

Air Inlet And Priming

To start the pump, slightly open the air shut-off valve. After the pump primes, the air valve can be opened to increase air flow as desired. If opening the valve increases cycling rate, but does not increase the rate of flow, cavitation has occurred. The valve should be closed slightly to obtain the most efficient air flow to pump flow ratio.

EXPLODED VIEWS FOR MC07 NON-METALLIC PUMPS

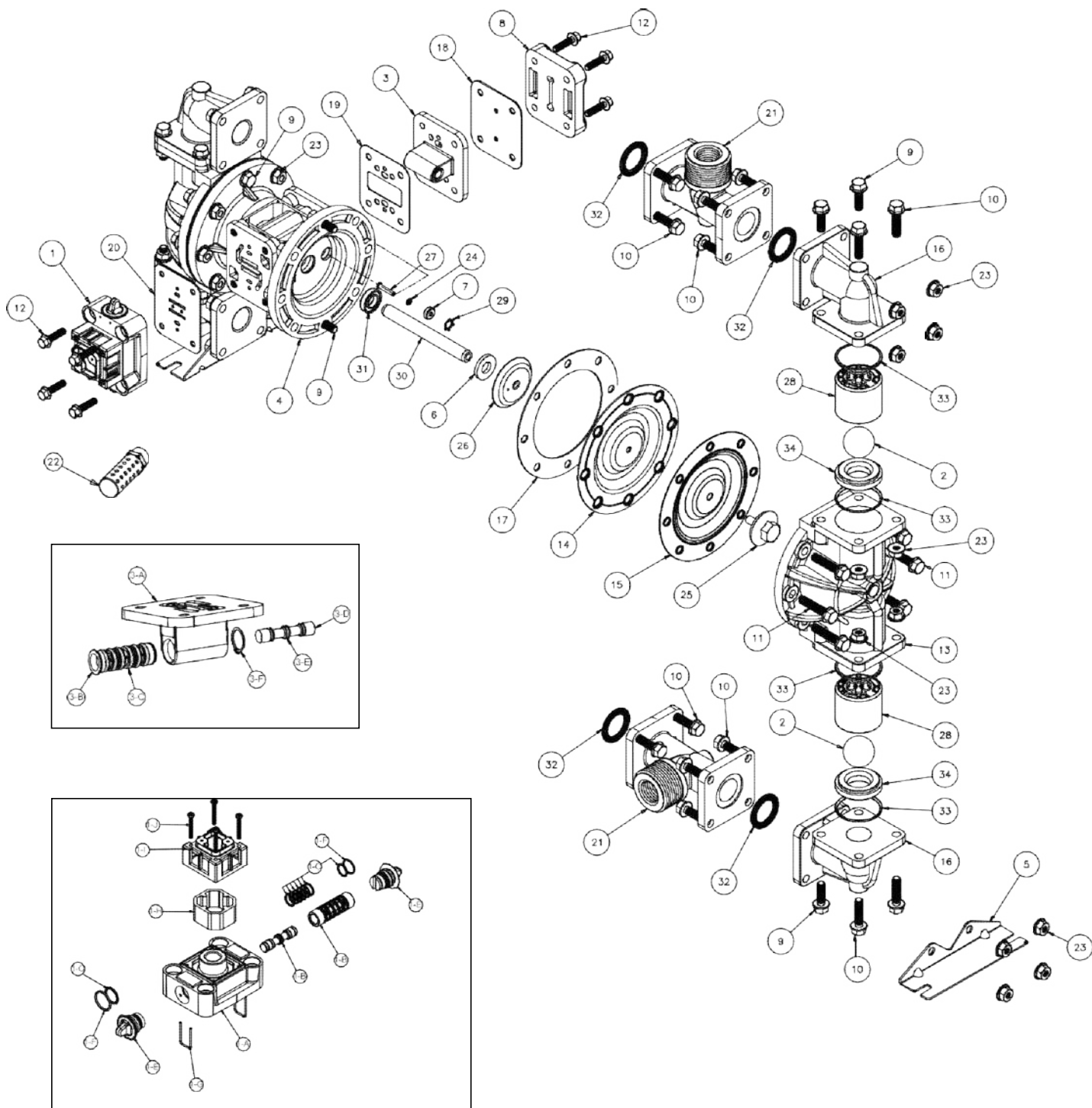

3: EXP VIEW

MC07 Non-Metallic Pump Parts List

S/N	Item	Part Number	Description	Qty	Mtl
1	1	MC031.166.000	Air Valve Assembly	1	Glass Filled PP
2	1	MC031.168.000	Air Valve Assembly(No Muffler)	1	Glass Filled PP
3	1-A	MC095.106.551	Body, Air Valve	1	Glass Filled PP
4	1-B	MC031.132.000	Sleeve and Spool Set	1	Alumminum
5	1-C	MC560.101.360	O-Ring	8	Nitrile
6	1-E	MC165.122.551	End Cap	2	Glass Filled PP
7	1-F	MC560.026.360	O-Ring	2	Nitrile
8	1-G	MC675.062.115	End Cap Retainer	2	Stainless Steel
9	1-H	MC530.031.550	Muffler	1	PE
10	1-I	MC165.109.551	Muffler Cap	1	Glass Filled PP
11	1-J	MC710.011.115	Self-Tapping Screw	4	Stainless Steel
12	2	MC050.028.600	Ball,Check,PTFE	4	PTFE
13	2	MC050.028.354	Ball,Check,Santoprene	4	Santoprene
14	2	MC050.028.356	Ball,Check,Hytrel	4	Hytrel
15	2	MC050.028.360	Ball,Check,Nitrile	4	Nitrile
16	2	MC050.028.363	Ball,Check,FKM	4	FKM
17	2	MC050.028.364	Ball,Check,EPDM	4	EPDM
18	2	MC050.028.365	Ball,Check,Neroprene	4	Neoprene
19	3	MC095.091.000	Pilot Valve Assembly	1	Glass Filled PP
20	3-A	MC095.087.551	Valve Body	1	Glass Filled PP
21	3-B	MC755.051.000	Sleeve(with O-Rings)	1	Alumminum
22	3-C	MC560.033.360	O-Ring(Sleeve)	6	Nitrile
23	3-D	MC775.055.000	Spool(with O-Rings)	1	Stainless Steel
24	3-E	MC560.023.360	O-Ring(Spool)	3	Nitrile
25	3-F	MC675.037.080	Retaining Ring	1	Carbon Steel
26	4	MC114.023.551	Bracket,Intermediate	1	Glass Filled PP
27	5	MC115.142.115	Bracket,Mounting	2	Stainless Steel
28	6	MC132.034.360	Bumper,Diaphragm	2	Nitrile
29	7	MC135.036.506	Bushing,Plunger	2	POM
30	8	MC165.110.551	Cap,Air Inlet	1	Glass Filled PP
31	9	MC171.062.115	Capscrew,Flanged 5/16-18*1.00	8	Stainless Steel
32	9	MC171.075.115	Capscrew,Flanged 5/16-18*0.875	4	Stainless Steel
33	10	MC171.063.115	Capscrew,Flanged 5/16-18*1.25	24	Stainless Steel
34	11	MC171.064.115	Capscrew,Flanged 5/16-18*1.50	12	Stainless Steel
35	12	MC171.066.115	Capscrew,Flanged 1/4-20*1.25	8	Stainless Steel
36	13	MC196.162.552	Chamber,Outer	2	PP
37	13	MC196.162.520	Chamber,Outer	2	PVDF
38	14	MC286.095.354	Diaphragm	2	Santoprene
39	14	MC286.095.356	Diaphragm	2	Hytrel
40	14	MC286.095.360	Diaphragm	2	Nitrile
41	14	MC286.095.363	Diaphragm	2	FKM
42	14	MC286.095.364	Diaphragm	2	EPDM
43	14	MC286.095.365	Diaphragm	2	Neoprene
44	15	MC286.096.600	Diaphragm	2	PTFE

S/N	Item	Part Number	Description	Qty	Mtl
45	16	MC312.107.552	Elbow	4	PP
46	16	MC312.107.520	Elbow	4	PVDF
47	17	MC360.099.360	Gasket,Spacer(use w/TPE Diaphragms only)	2	Nitrile
48	18	MC360.100.360	Gasket,Air Inlet	1	Nitrile
49	19	MC360.101.360	Gasket,Pilot Valve	1	Nitrile
50	20	MC360.102.360	Gasket,Air Valve	1	Nitrile
51	21	MC518.139.552	Manifold	2	PP
52	21	MC518.139.520	Manifold	2	PVDF
53	22	MC530.024.000	Muffler,Metal	1	Carbon Steel
54	23	MC544.005.115	Nut,Flanged 5/16-18	36	Stainless Steel
55	24	MC560.001.360	O-Ring	2	Nitrile
56	25	MC612.091.552	Plate,Outer Diaphragm	2	PP
57	25	MC612.091.520	Plate,Outer Diaphragm	2	PVDF
58	26	MC612.177.330	Plate,Inner Diaphragm	2	Zinc Plated Steel
59	27	MC620.019.115	Plunger,Actuator	2	Stainless Steel
60	28	MC670.050.552	Retainer,Ball	4	PP
61	28	MC670.050.520	Retainer,Ball	4	PVDF
62	29	MC675.042.115	Ring,Retaining	2	Stainless Steel
63	30	MC685.056.120	Rod,Diaphragm	1	Stainless Steel
64	31	MC720.012.360	Seal,Diaphragm Rod	2	Nitrile
65	32	MC720.046.600	Seal,Manifold	4	PTFE
66	33	MC720.051.600	Seal,Check Valve Retainer	8	PTFE
67	34	MC722.081.552	Seat,Check Valve	4	PP
68	34	MC722.081.520	Seat,Check Valve	4	PVDF